

Dozaj Kantarı

Dosage Scale

Весы Дозаторы



“Precision Measurement for Consistent Feed Quality”

The Dosage Scale provides precise measurement of raw materials, ensuring consistent feed formulations. Advanced sensors and intelligent control systems prevent over- or under-dosing, maintaining nutritional balance in every batch.



High Performance

Высокая
производительность



Less Energy

Меньше
Энергии



Maximum Capacity

Максимальная
емкость



KM KAR-MILL
MACHINERY INDUSTRY

Engineered for modern feed production lines, the Dosage Scale operates quickly and efficiently, reducing manual handling and minimizing production errors. This helps maximize overall plant productivity while ensuring consistent product quality.

Built from durable, wear-resistant materials, the Dosage Scale offers long-term reliable operation under industrial conditions. Easy access for maintenance and cleaning ensures minimal downtime and uninterrupted feed production.

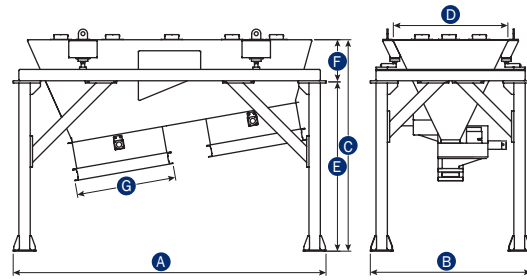
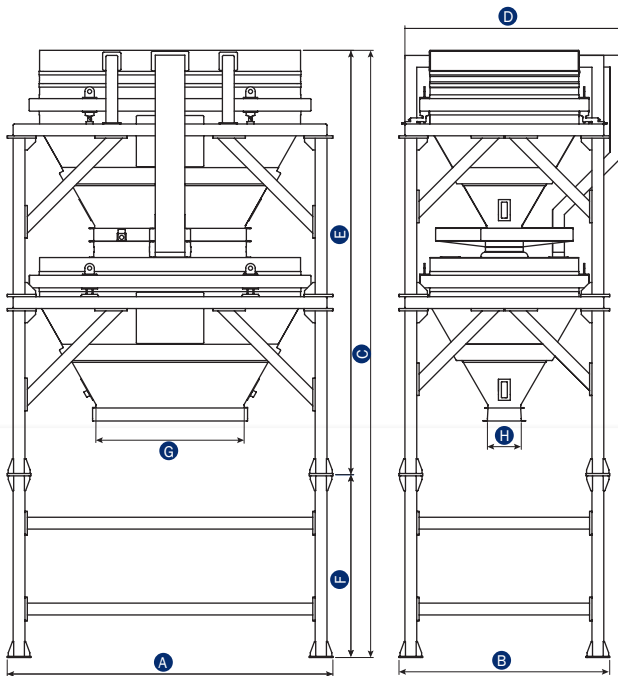
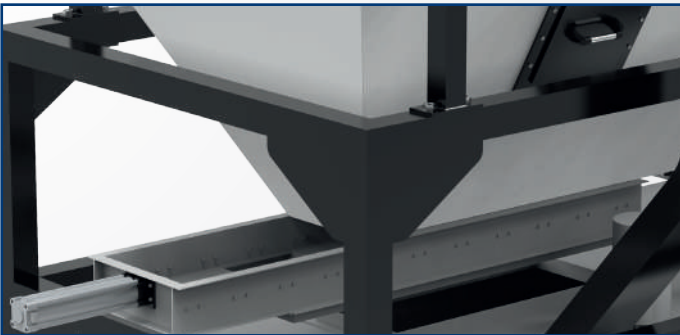

Type Model	Hopper Volume (Cbm) Kefe Hacmi	Weight Ağırlık
KRM-DS 095	0.95	800
KRM-DS 223	3.34	2090
KRM-DS 467	6.80	2985
KRM-DS 715	10.03	3650

Type Model	A	B	C	D	E	F	G	H
KRM-DS 095	2753	1413	1861	1008	1490	371	876	220
KRM-DS 223	2755	1780	5665	1835	4120	1545	1250	280
KRM-DS 467	4350	1930	5720	1970	4060	1660	2690	270
KRM-DS 715	5050	2130	6705	2175	4470	2235	3490	270