

Pelet Presi

Pellet Press

Пеллетный Пресс



“Superior Feed Quality through Homogeneous Pelletizing”

Our pellet presses combine efficiency and quality in feed production, delivering homogeneous pellets that retain their nutritional value thanks to their durable structure and high compression force. With their advanced design, they offer maximum production capacity while ensuring low energy consumption.



High Performance
Высокая
производительность



Less Energy
Меньше
Энергии



Maximum Capacity
Максимальная
емкость

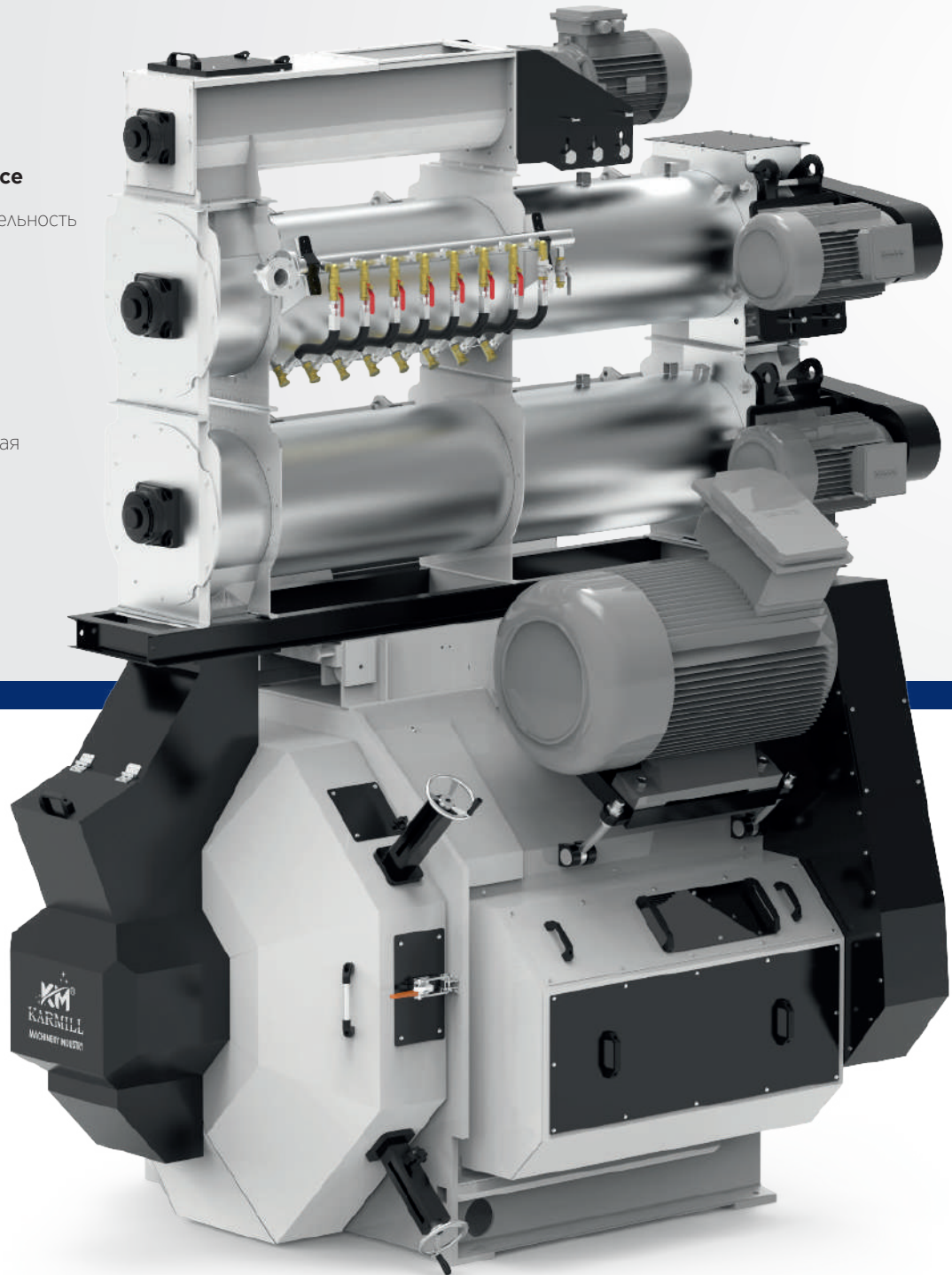

Our pellet presses deliver high efficiency and superior quality in feed production, ensuring the preservation of nutritional value through homogeneous pelletizing technology while producing durable and uniform pellets. With their robust body structure, high compression force, and precision processing features, they provide long-lasting performance.

Thanks to their advanced mechanical systems and energy-efficient design, they offer maximum production capacity with minimum operating costs. Their flexible operating capabilities make them suitable for various raw material types, providing the most effective solutions to meet the production needs of feed mills.

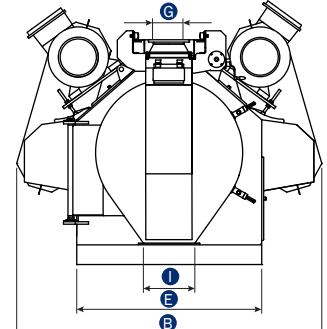
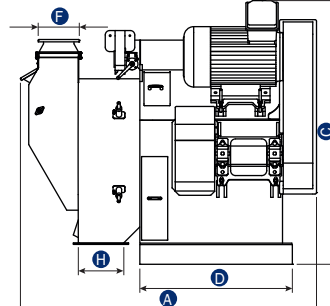
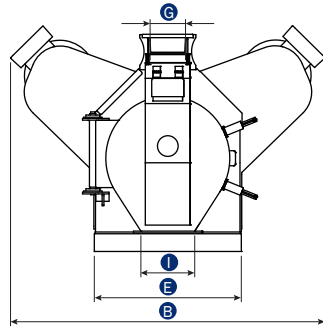
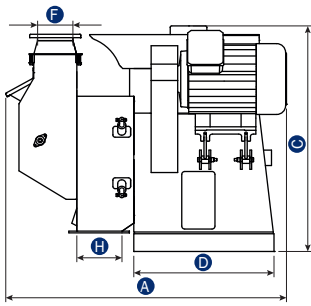
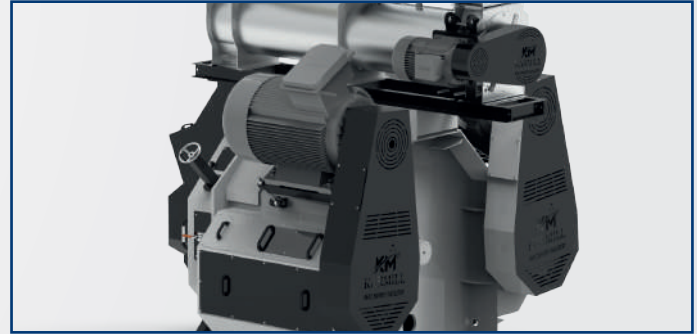
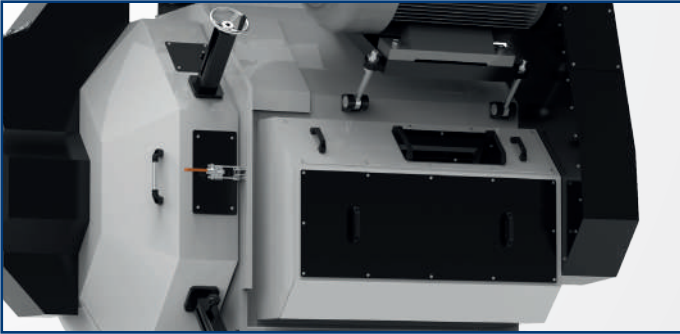
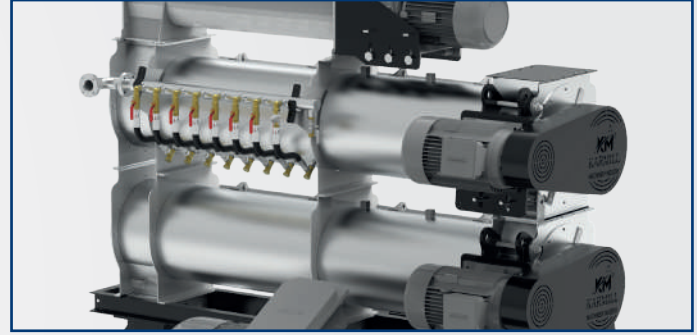

Type Model	A	B	C	D	E	F	G	H	I
KRM-PP 420	1890	2180	1585	1000	995	235	235	310	365
KRM-PP 520	2410	2890	2150	1300	1250			300	300
KRM-PP 660	2575	3150	2090	1400	1400			400	400
KRM-PP 800	2790	3340	2740	1550	1880	300	300	460	520

Type Model	Inner Dia İç Çap (mm)	Width Pelet Geniřliđi (mm)	Area Pelet Alanı (m2)	QTY Adet	Dia Çap (mm)	Motor Power Motor (kW)	Weight Ađırlık
KRM-PP 420	420	138	0.18	2	200	2x(45/55)	3495
KRM-PP 520	520	178	0.29		240	2x(90/110)	6450
KRM-PP 660	660	228	0.47		320	2x(110/132)	7890
KRM-PP 800	800	265	0.67		360	2x(132/160)	11525